



16/2-6 Arthur Avenue CRONULLA NSW

3 2 1

Lifestyle - UNDER CONTRACT Positioned right on the The Esplanade and garnering a stunning coastal panorama from its open plan living areas and large ocean-front balcony, this spacious contemporary apartment is in the tightly-held 'Rugby' complex. Short stroll to shops, cafes, Cronulla Beach

Accommodation - A generous house-like layout offers three large bedrooms along a central hall, with the master bedroom boasting an ensuite and built-in wardrobes. Separate L-shaped living/dining areas adjoin a smart modern kitchen and there is a servery through to the dining area

Features - A private sixth floor outlook, ocean views from every room and no common walls makes this apartment an

Land Size : 156 sqm

View : <https://www.gibsonpartners.com/sale/nsw/sutherland/cronulla/residential/apartment/5854922>



Denise Howell
02 9523 1333

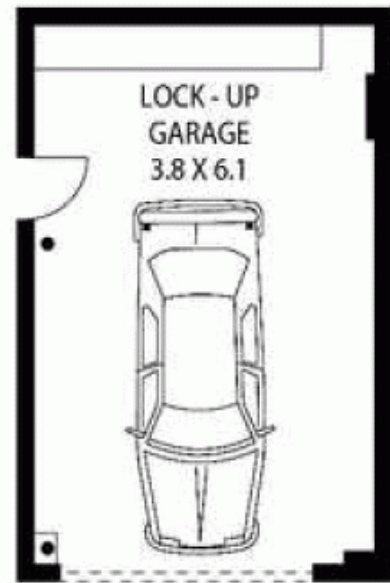

LEVEL SIX

16/2-6 ARTHUR AVENUE

CRONULLA

***Disclaimer:** mtg - mind the gap floor plans & site plans are intended as a guide only. Individuals should always rely on their own enquiries for exact measurements and no warranties are intended or given. Please Note: Any internal area measurement total that may be included does not include any void spaces or recesses. Any external area measurement total that may be included does not include the total site plan area (i.e. total grounds and garden areas). mtg - mind the gap - 1300 133 145 - www.mindthegap.com.au