

16/137 Willarong Road Caringbah NSW

2 2 1

Positioned in the innovative 'Aria' development and occupying a prized northerly aspect, this executive style 2 bedroom apartment boasts spacious light filled interiors and sophisticated quality inclusions throughout.

Price : \$ 580,000

View : <https://www.gibsonpartners.com/sale/nsw/sutherland/caringbah/residential/unit/5853770>

Enjoying an ultra-convenient location, this low maintenance abode is situated within a stone's throw to Caringbah Shopping Village that plays host to cafes, restaurants, train station and parks.

- Ultra modern development, first floor position and bathed in northern sun
- Spacious lounge and dining area with adjoining entertainer's balcony
- Caesar stone kitchen with stainless steel appliances and gas cook top



Ivan Lampret
02 9523 1333



Karla Madgwick
02 9523 1333

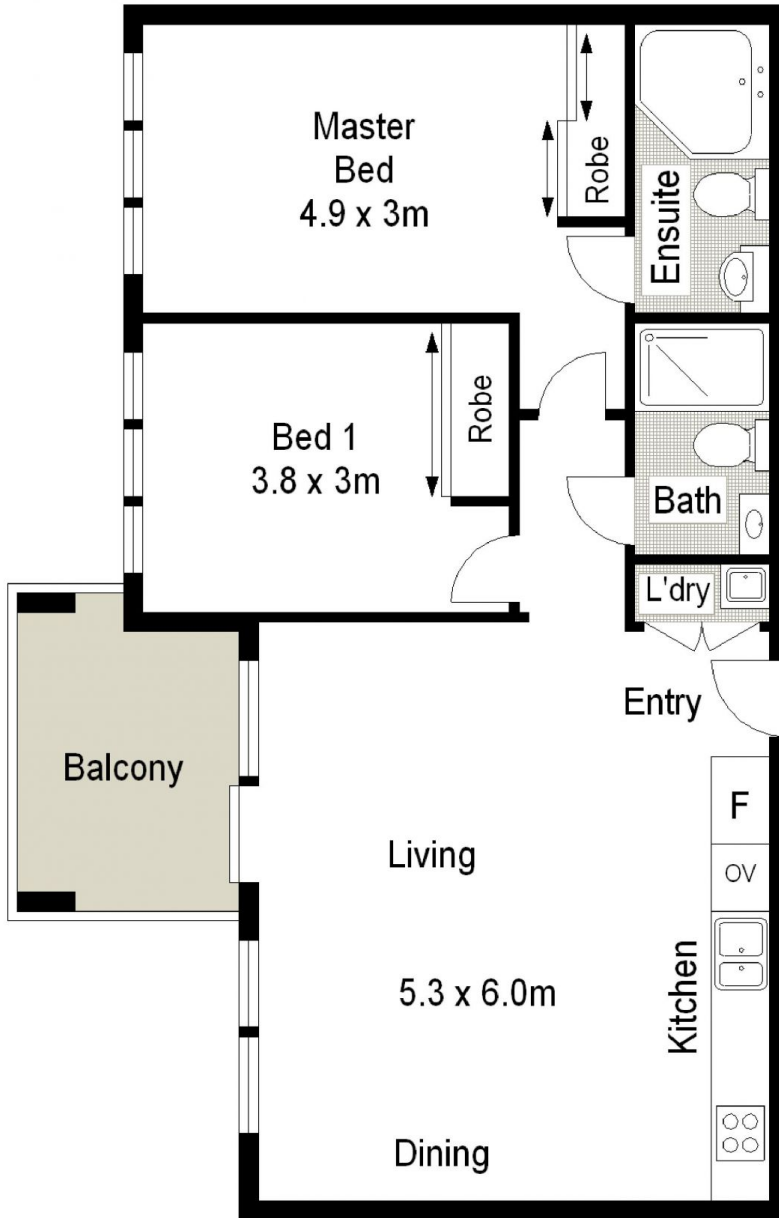

FIRST FLOOR

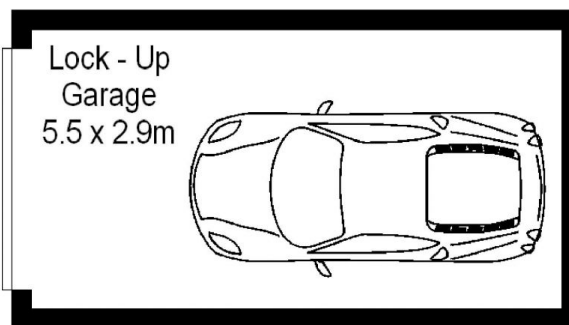

BASEMENT

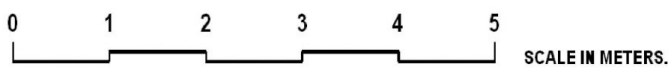

Gibson Partners Real Estate Pty Ltd

Scale in metres. Indicative only. Dimensions are approximate. All information contained herein is gathered from sources we believe to be reliable. However we cannot guarantee its accuracy and interested persons should rely on their own enquiries.

