



2/711 Kingsway GYMEA NSW

2 1 1

Within an easy stroll to Gymea's Village of shops, cafs and restaurants, and only 250m (approx.) to the train station, this spacious 2 bedroom apartment boasts an elevated ground floor position, a sunny westerly aspect and an ideal opportunity for first home buyers trying to enter the market.

View : <https://www.gibsonpartners.com/sale/nsw/sutherland/gymea/residential/apartment/5853159>

The apartment offers a great floor plan and a fantastic opportunity for those with a creative flair to add their personal touch.

- * 2 good size bedrooms both with built-in robes
- * Large bathroom with separate bath & shower
- * Updated kitchen & internal laundry
- * Separate lounge and dining areas
- * Sunny west facing balcony
- * Security access and lock-up garage



Ivan Lampret
02 9523 1333

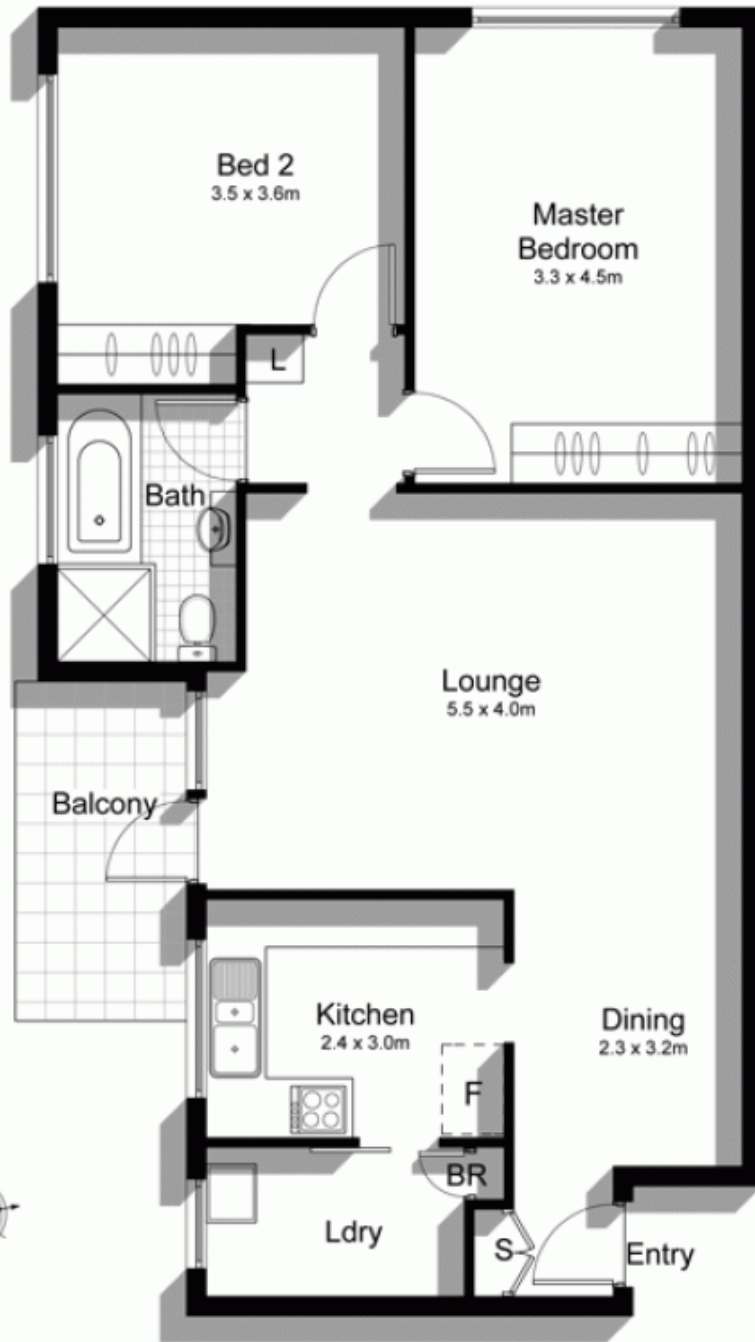
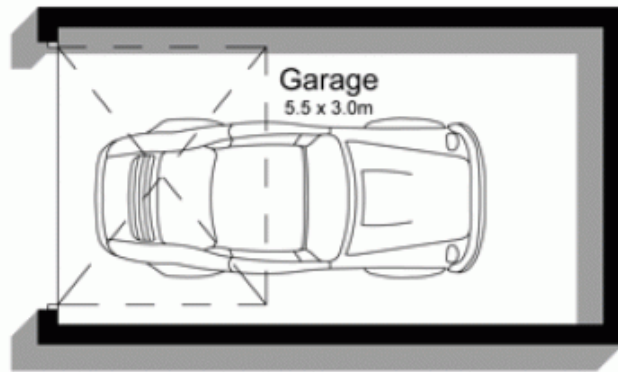

2/711 Kingsway
GYMEA

DISCLAIMER: All care has been taken in preparing this floor plan, however the accuracy is not guaranteed and no liability will be accepted for any reliance placed upon it
Produced by PRODUCT PHOTOGRAPHY STUDIO
mob: 0414 697 215 email: mgphoto@people.net.au